

**DigiFan DF-500** is a powerful and versatile special wind machine designed for studios, theaters, theme parks, touring, photographic and more. It is suitable for wide range application including blowing haze, smoke, bubbles, confetti or snow, cooling performers, dimmer racks or amplifiers even drying paint in studio. DF-500 can be controlled through standard DMX signal or master/slave operation through data link.

- Versatile yoke for overhead rigging, floor sitting or stand mounting.
- Housing is constructed from a molded lightweight plastic venting device with rugged tubular steel surrounded for transport and protection.
- The 11" one-piece blade and spiral front grill for creating narrow focus wind stream.
- Compact, lightweight and powerful.



**Specification:**

- Power input: 80-240V AC, 1200W, Current Max. 10A.
- One touch turbo function: 0-3500RPM within 5 sec.
- DMX mode: DMX on-off and volume control
- Memory: 9 mode memory setting available
- Remote controller: Supplied w/3M cable
- Motor: 500W, Max. 3500RPM
- Air volume: 1700CBM/hr
- Wind speed: 60KM/hr
- Dimension: 480x560x460mm
- Weight: 12.5Kg



**Four reasons DigiFan makes a vortex wind effect:**

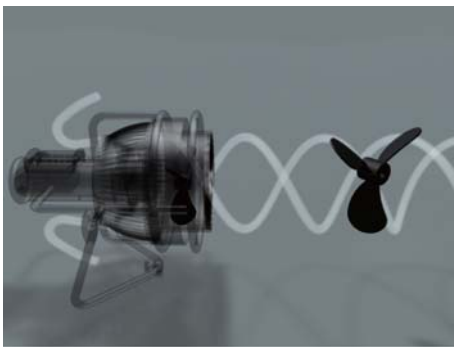

11" one piece deep pitch blade churn through the air, maximizing the amount of the air moved with the each turn of powerful motor.



The spiral shape designed front grill offset the direction of the air as it twists off the blade. This allows the air to travel long distance.



Air inlet duct tube ensures that the deep blade are fully enclosed in a cylindrical duct, air is sculpted into a column (beam of air).

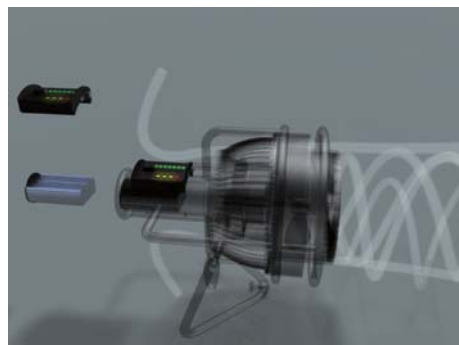

To combine deep pitch blade, spiral grill, ducted tube and a switching power supply the multi function Digi fan is able to create a fully controllable vortex wind effect.